

LED-EMG-05WCP

Version: A1

Page: 1/1

5W Constant Power - Direct Input - Emergency Driver

1 Dimensions

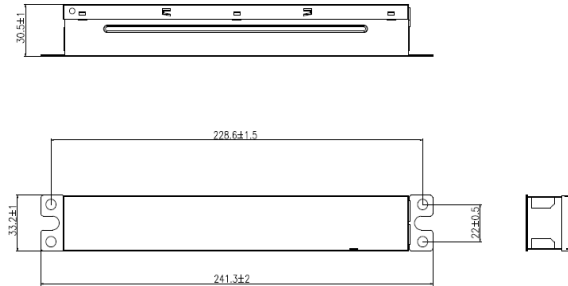

Dimension	Length
H	30.5mm (1.2 in)
W	33.2mm (1.3 in)
L	241.3mm (9.5 in)
M	228.6mm (9.0 in)

2 Electrical Characteristics

Input Information	Input Voltage	120-277V AC
	Frequency Range	50/60Hz
	Max. Power	5W
	Max.standby Power	1.8W
Output Information	Output Power	5W
	Emergency Time	90 min.@5W
	Output open protection	Yes
	Over power protection	Yes
Others Information	Compatibility	Internal / < 30W drivers
	Operation Temp.	0°C-50°C
	Battery Type	Lithium-Ion
	Battery Capacity	850mAh 14.8V
	Charge Current	160mA
	Recharge Time Required	24 Hours MAX.
	UL Conditions of Acceptability	Battery temperature should not exceed 50°C
Warranty	5 Years Warranty	

3 Wiring Diagrams

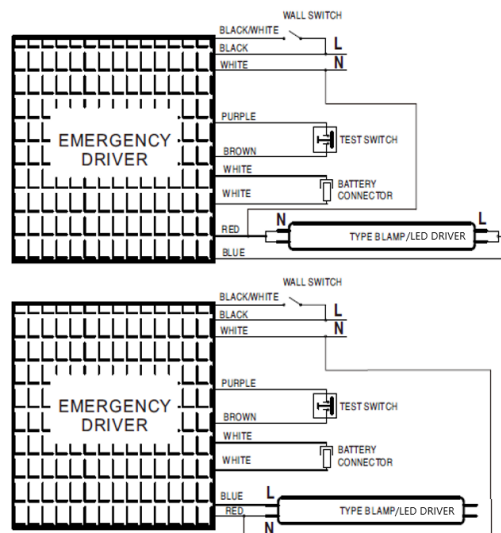

Wire Color	Wire Length
White	800mm (31 in)
Black-White	650mm (25 in)
Black	800mm (31 in)
Red	1200mm (48 in)
Blue	1200mm (48 in)
Purple	1200mm (48 in)
Brown	1200mm (48 in)
White	320mm (12in)
White	320mm (12in)

4 Certification

UL 924 and FCC